

IS-ACTIVE

Inertial Sensing System for Advanced Chronic Condition
Monitoring and Risk Prevention

WP2 – Architecture

Document ID:	D2.2
Document title:	Architecture Specification
Document type:	Deliverable
Contributors:	<u>UI</u> , RRD, INE, NOR

Document history

Vers.	Date	Modification	Authors
1	01-12-2009	First set-up of document	UT, INE
2	04-12-2009	Added detailed sections in ToC	UT, INE
3	08-12-2009	Added block diagram	UT, INE
4	09-01-2010	Updated Section 1, 3, 5 and 7	UT, INE, RRD
5	18-01-2010	Updated Section 6	INE, RRD, NOR
6	19-01-2010	Updated Section 4	UT, INE
7	19-01-2010	Updated Section 2	RRD, UT
8	19-01-2010	Updated Section 7	INE, RRD
9	20-01-2010	First integrated draft	UT, INE
10	26-01-2010	Included comments from NST/NOR	NST, NOR, INE
11	27-01-2010	Removed text from requirement 4.5	NST, NOR

Table of contents

1. Overview	4
2. Relation to requirements analysis	4
2.1. Scenarios	4
2.2. Functional components	4
2.3. Exercises	8
3. Main architectural components	8
4. Wireless sensors networks (WSNs)	10
4.1. Sensor node	10
4.2. Sensors networking	11
4.3. WSN focus in IS-ACTIVE	12
5. Interactive devices	12
5.1. Technology aided objects (TAOs)	13
5.2. On-body sensors	14
5.3. Feedback devices	14
6. Infrastructure	18
6.1. Home-based infrastructure	18
6.2. Multiple users/patients	19
6.3. Communication with the caregiver	19
7. Functional overview	21
7.1. Activity monitoring	22
7.2. Exercise coaching	23
8. Conclusions	24
9. References	24

1. Overview

This document describes the IS-ACTIVE architecture, in close relation to the functional requirements and use cases, on the one hand, and the system characteristics and technical developments, on the other hand. The document is organized as follows. Section 2 points back to the requirements analysis deliverable D2.1. Section 3 presents the main building blocks of the IS-ACTIVE architecture, offering a top-level architectural view. Sections 4, 5 and 6 go into the detailed technical specification of the three major components: wireless sensor networks, interactive devices and infrastructure, respectively. Section 7 gives the functional architectural overview, namely how the building blocks connect to each other to provide the desired functionality. Finally, Section 8 concludes the document.

2. Relation to requirements analysis

This section reiterates the important results of the requirement analysis, as these form a starting point in defining the architecture.

2.1. Scenarios

The clinical partners ELS, NST and RRD developed scenarios in order to serve as a basis for discussions within the project, to put ideas forward on what to do, and to provide information for partners with less knowledge about COPD and exercising.

The scenario of ELS describes a 63 year old COPD patient (GOLD IIa), who wants to improve his lifestyle by using the IS-ACTIVE system. The scenarios of NST describe two different COPD patients who both want to improve their physical condition within their capacity: Erik (58 years, GOLD II) , who wants to take part in his former outdoor activities again, and Sonja (70 years, GOLD III-IV), who wants to get back into the social activity of LHL dancing. The RRD scenario describes COPD patient Bob (62 years, GOLD III), who wants to improve his physical condition by receiving personal context-aware feedback from the IS-ACTIVE system through daily activity monitoring.

The full description of the scenarios can be found in deliverable D2.1.

2.2. Functional components

The following two tables divide the functional requirements from D2.1 into requirements that will be considered, requirements that will not be considered and so-called "nice to have", requirements that will not be focussed on mainly, but would be a nice addition to the system.

Some requirements include some additional clarification that could be needed to derive technical specifications from them.

Will be considered	
1.1	The system must monitor activity, daily activities, and breathing (see 1.2, 1.3 and 1.5) by inertial sensors inside and outside the house, when the patient wears the IS-ACTIVE system.
1.2	The system must monitor the amount of activity, the activity pattern (distribution of activities over the day), and activity intensity.
1.3	The system must detect the type of daily activities walking, walking stairs, and in

	<p>addition:</p> <ul style="list-style-type: none"> - cycling (outdoor) - walking uphill/downhill - walking stairs up/down
1.4	The system must measure the duration of the activities stated in 1.3,
1.6	The system must monitor the saturation and heart rate during exercise or intense activities by choice of the patient.
1.7	The sensors besides the inertial sensors must be equipped with a Bluetooth connection.
1.11	It must be possible to enter information manually through a feedback device in case the sensors are not able to correctly detect activities.
2.1	The system must include fitness devices with incorporated inertial sensors, for monitoring treatment progress (see 3) and provide feedback during the exercises (see 6).
2.2	Inertial sensors must be attached to the bicycle (outdoor) of the patient.
2.3	Inertial sensors must be attached to the bicycle (indoor) of the patient.
2.4	The system must use information from the weather outside and the location of the patient for context-aware feedback (see 5.6).
3.1	The system must be able to set a personal treatment goal of the patient in order to improve physical condition, quality of life and prevent exacerbations.
3.2	The physiotherapist (all) OR rehabilitation physician (ELS) must be able to adapt and approve the treatment goal set by the system.
<p>Clarification 3.2:</p> <p>The treatment goals like the amount and spread of activity a patient should adhere to, as well as the type and frequency of exercises must always be confirmed by a real person. Whether the patient himself, a physiotherapist or a rehabilitation physician does this is to be decided in the protocol of the IS-ACTIVE treatment. In any case, the patient should have knowledge of the goals set by the system and must approve them in order to increase the likelihood of adherence.</p>	
4.1	The system must provide exercises for the patient to train interactively using fitness devices with incorporated inertial sensors and the on-body sensors (see 1).
4.2	The executed movements of the patient during exercises must be shown on a feedback device when the patient is exercising OR exercises must be incorporated in virtual games on a feedback device.
4.3	The system must register when, how often, and for how long the patient performs exercises.
4.5	The system must comprise group training and exercises, so the patient can perform the normally individual exercises in a group. The patients belonging to one group must be networked.
5.1	The system must keep track of the personal treatment goal based on the measured sensor data of the patient and should propose exercises AND/OR activity in order to accomplish the treatment goal.
5.2	The system must recognize the trends after feedback and learn from the feedback

	provided, and use the type of feedback that is the most effective for the patient.
5.3	The system must be able to give feedback both inside, and outside a patient's home, as well when the patient is on the move.
5.4	The system must be able to detect personal preferences of the patient (like walking or cycling) and the patient must be able to fill in personal preferences as well into the system.
5.5	The feedback must be tailored and personal - the system automatically adapts the feedback to the patient's personal preferences and health status.
5.6	The feedback must be context-aware, by making use of information regarding the patient's surroundings.
6.1	The feedback during exercise must be focused on the right execution of the exercises (based on data from on-body sensors and sensors embedded in fitness devices), activity intensity, and safety (based on breathing, heart rate and saturation parameters).
6.2	Feedback must be provided during exercises on a feedback device, in a motivating manner, so the patient feels guided and motivated.
6.3	The patient must be noticed when saturation levels are too low (threshold determined by the system, and approved by the physiotherapist) and/or heart rate is too high (threshold determined by the system, and approved by the physiotherapist) and/or on-body parameters indicate severe dyspnoea (determined by the system). Otherwise, these parameters must not be shown to the patient during exercise.
7.1	The feedback during activities in daily life must be focused on the amount of activity, based on the personal treatment goal and in addition <ul style="list-style-type: none"> - must be focused on the right distribution of activities over the day based on the personal treatment goal. - must provide feedback to the patient to prevent extreme dyspnoea (based on the data from the on-body sensors, determined by the system).
7.2	Feedback must be provided automatically by the system on a feedback device about the patient's daily activities in a motivating manner.
7.3	In case the patient wears the optional sensors during daily physical activities, the patient must only be noticed when measured saturation levels are too low (threshold determined by the system, approved by the physiotherapist) and/or heart rate is too high (threshold determined by the system, approved by the physiotherapist).
8.1	The patient needs to log in to gain access to the data.
8.2	The amount of activity and the activity pattern must be accessible for viewing on a feedback device with a graphical view by hour, daily period, day, week, month and year, depending on the type of feedback device together with the personal treatment goal and the progress (e.g. % of treatment goal achieved, or reference line).
8.3	Results of the exercises (see 4.3) must be visualized on a feedback device together with the personal treatment goal.
8.4	The system must generate weekly reports about the patient's status, including the amount of activity, activity pattern, results of the exercises, personal goals and

	progress information. This could be incorporated in a Personal Health Record so the patient can monitor his/her progress.
Clarification 8.4:	
Progress reports should show daily, weekly and monthly overviews of the patient's performance.	
9.4	The patient must be able to choose the amount of supervision (no supervision option: patient sets own goals, or professional supervision option: physiotherapist sets goals, and extra guidance sessions with physiotherapist).
Clarification 9.4:	
This requirement is mainly an issue of treatment protocol.	

Will not be considered	
1.4	The system must continuously monitor the distance and speed of cycling (outdoor).
1.4	The system must continuously monitor the distance and speed of walking.
1.5	The system must continuously monitor breathing by the respiratory rate.
1.5	The system must continuously monitor the expiratory time.
1.5	The system must continuously monitor cough.
1.8	The system must monitor breathing and saturation at night to detect sleep apnoea.
1.10	The system must monitor vegetative skin response and skin conductance.
2.5	The device must measure the quality of air (temperature, humidity, dust, smoke, and pollen).

Nice to have	
1.9	The system must monitor posture (standing, sitting, lying).
2.6	The system must include an electronic diary to predict exacerbations.
4.4	The patient must always be able to gain information about how to perform exercises in a visual and auditory manner on a feedback device.
9.1	The physiotherapist OR a nurse (preferably pulmonary) (NST) must have access to the patients data in order to monitor progress by the Personal Health Record by a personal log in.
9.2	The device must generate weekly reports about the patient's status, with all the measured data. This could be incorporated in a Personal Health Record so the healthcare professional (see 9.1) can monitor the patient's progress.
9.3	The healthcare professional (see 9.1) must be able to send a personal message to the feedback device of the IS-ACTIVE system of the patient.

2.3. Exercises

The following two tables divide the exercises from D2.1 into exercises that will be considered and those that will not be considered.

Will be considered	
Exercise 4	Cycling
Exercise 5	Walking
Exercise 8	Rotation
Exercise 10	Extension
Exercise 11	Rotation
Exercise 12	M.biceps brachii
Exercise 13	M. serratus anterior
Exercise 14	Mm. quadriceps
Exercise 15	Mm. quadriceps
Exercise 16	Weight circles
Exercise 17	Rubber band exercise
Exercise 18	M. quadriceps

Will not be considered	
Exercise 1	Pursed-lips breathing
Exercise 2	Chest/side/diaphragmatic breathing
Exercise 3	Optimise diaphragm function
Exercise 6	Huffing
Exercise 7	Coughing
Exercise 9	Lateral flexion
Exercise 19	Pilates I
Exercise 20	Pilates II

3. Main architectural components

Figure 1 presents the top-level view on the main architectural components taken into account by IS-ACTIVE. We distinguish the following important building blocks:

- *Wireless sensors networks (WSNs)* - the core technology of IS-ACTIVE, creating a pervasive environment around the user:
 - On-body sensors, such as inertial sensors (used for the analysis of user motions, activity monitoring and exercise coaching) and physiological sensors (used for checking safety limits of user's current condition). The on-body sensors form the *Body Sensor Network (BSN)*.
 - Infrastructure sensors, such as environmental sensors (used for signaling possible adverse environmental conditions with respect to the user specific condition).

- *Technology-aided objects (TAOs)* – technology-enhanced daily objects (for indoor or outdoor usage) that contribute to monitoring and assessing the physical training performance of patients. They are mainly graspable objects with which the users carry out training task at home and outdoors. Together, the on-body sensors and TAOs form the *Extended Body Sensor Network (BSN+)*.
- *Feedback devices* – covering all user interaction aspects, providing the information sensed and processed by the WSN in a simple and appealing way to the user. The main objective here is to enhance the user motivation for physical activity.
- *Home-based infrastructure* – the wireless communication infrastructure (hardware and software) interconnecting the above components (WSNs, technology-aided objects and feedback devices) in a seamless way.
- *Multiple users/patients* – providing multiple patients with the possibility of exercising and using together the IS-ACTIVE system.
- *Communication with the caregiver* – two-way connection with the care center that allows the latter to assess the progress of the patient, as well as to give proper advice adapted to the current status and evolution of the disease.

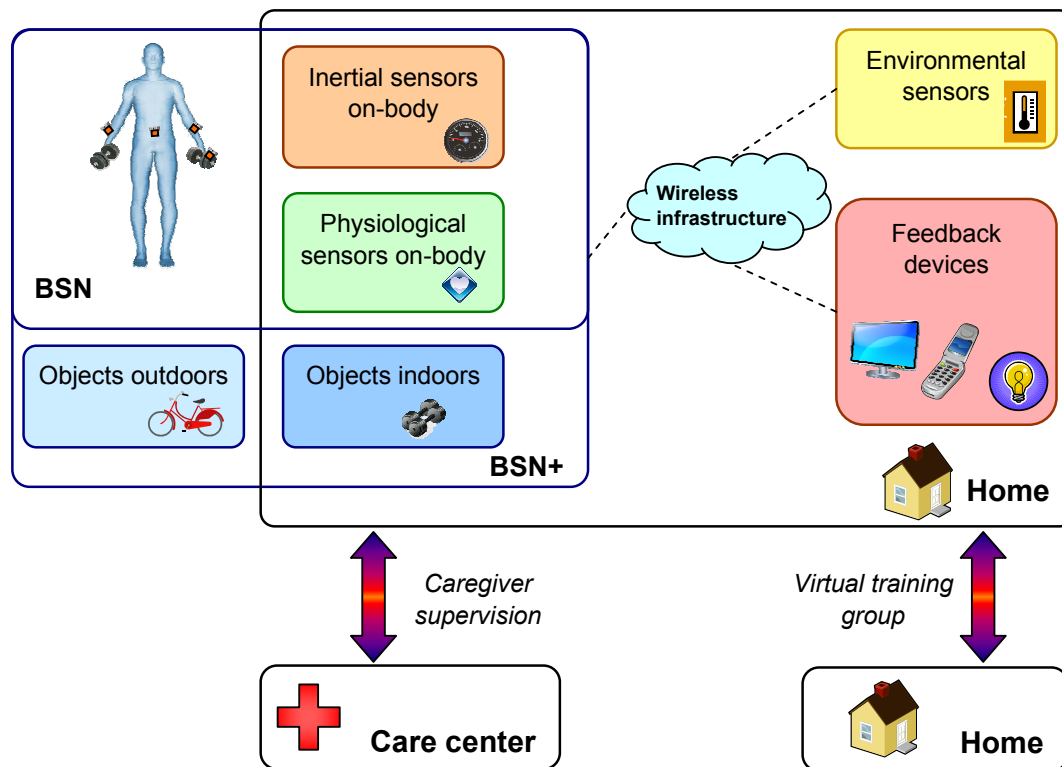

Figure 1 - Block diagram of IS-ACTIVE system architecture

4. Wireless sensors networks (WSNs)

The objective of this section is to demonstrate the hardware and software building blocks of sensor nodes used in the development of the IS-ACTIVE wireless sensor network. Besides, this section includes information about the relevant networking protocols and also considers some of the critical networking issues.

4.1. Sensor node

A sensor node is the main component of a wireless sensor network and it is capable of performing processing, communicating with other nodes in the network, and gathering required information from various sensors linked to the node. A sensor node has limited hardware resources, including the available power (usually a battery), therefore energy efficiency is an essential requirement for applications running on sensor nodes. A typical architecture for a sensor node is illustrated in Figure 2.

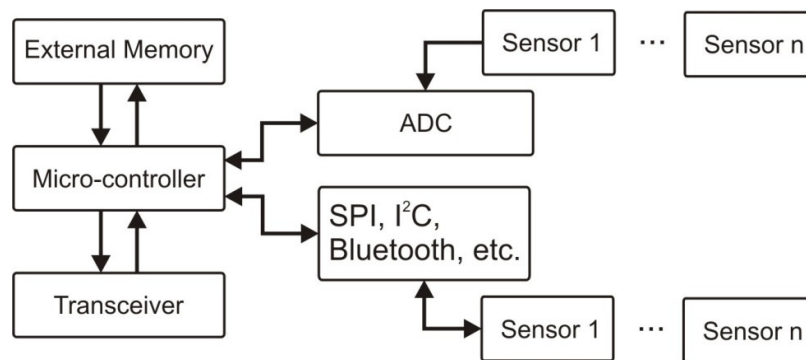

Figure 2 - Typical architecture for a sensor node.

Typical sensor nodes currently feature 8 or 16-bit microcontrollers, with flash memory in the order of 48kB and RAM in the order of 10kB. The communication is usually handled by a low-power wireless transceiver compatible with IEEE 802.15.4 and ZigBee®.

Since one of the main purposes of IS-ACTIVE is the motion sensing, inertial sensors (accelerometers and gyroscopes) and digital compasses should be incorporated with the sensor nodes. Beside these, physiological data (heart rate, oxygen saturation, etc.) needs also to be sensed. In order to handle this functionality, we are planning to integrate commercial off-the-shelf physiological sensors with wireless communication capabilities (like Bluetooth).

The access to the microcontroller, wireless transceiver, sensors and any other hardware resources is facilitated by a specific operating system or at least a hardware abstraction layer. Basically, the operating system is the interface responsible for coordination of activities and dealing with shared hardware and software resources. Figure 3 illustrates the interaction of the operating system with the whole system.

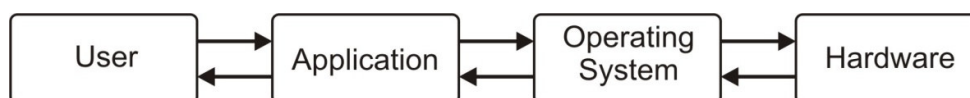

Figure 3 - Interaction between operating system and other software blocks

4.2. Sensors networking

A Wireless Sensor Network (WSN) is composed of sensor nodes that sense several environmental phenomena and form an ad-hoc network for the purpose of collaboratively processing and transmitting the data to the interested parties. A WSN is a self-organizing network that does not need user intervention for configuration or setting up routing paths. Therefore, WSNs can be used in virtually any environment, even in inhospitable terrain or where the physical placement is difficult [Sohr00].

Since WSNs differ largely from wireless networks, they require energy-preserving protocols and a suitable model to fit their dynamic topology. Therefore, WSNs do not fully adhere to the ISO-OSI reference model, which comprise the seven layers (Physical, Data Link, Network, Transport, Session, Presentation, and Application Layers) [Zimm80]. A more appropriate model for WSNs [Char09], with reference to OSI model, is illustrated as in Figure 4.

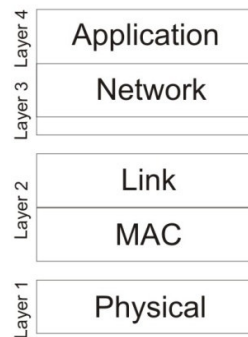

Figure 4 - WSN model

- The Physical Layer is responsible for the management of the wireless transceiver in following aspects:
 - Selection of operating frequency
 - Modulation scheme
 - Transmission power level
 - Data encoding
- The Data Link / MAC Layer is responsible for the shared access to the wireless medium and for regulating communication tasks within one-hop (i.e. one transmission range radius) neighborhood, namely:
 - Medium Access Control (MAC), which coordinates the usage of the wireless medium so that to minimize or eliminate the following: collisions, overhearing, control packet overhead and idle listening.
 - Error control, for example using automatic repeat-request (ARQ) or forward error correction (FEC).
- The Network Layer ensures the propagation of data packets from source nodes to destination nodes (or to the backend system) over multi-hop network paths. The two main blocks inside the network layer are:
 - Routing, which handles the actual forwarding of data packets on the path.
 - Transport, which deals with reliably transporting the data packets and decomposing and reassembling the message into/from data packets.

- The Application Layer implements the specific application running in the WSN and is often tightly coupled to the Network Layer for efficiency reasons.

The OSI Reference Model specifies the services provided by each layer and offers concepts to be used to specify how each layer performs. However, detailed functioning of each layer is defined by the specific protocols. IEEE 802.15.4 is a standard protocol that provide network infrastructure required for wireless sensor network applications and it defines the physical and MAC layers [Dain08]. Considering the requirements of sensor network applications, 802.15.4 is designed to provide long battery life, low-cost, small footprint, and mesh networking to support communication in large networks. Other than this, other important features of include real-time suitability by reservation of guaranteed time slots, collision avoidance through Carrier Sense Multiple Access with Collision Avoidance (CSMA/CA) and integrated support for secure communications [IEEE06].

Sensor nodes are the main building blocks of wireless sensor network applications and in many applications, sensor nodes will be battery powered. Changing or recharging batteries in relatively short intervals is impractical and reduces the usability and reliability of these systems. Therefore, sensor nodes spend most of their operational life in a sleep-state and periodically listen to the communication channel periodically in order to reduce power consumption. This mechanism allows the user to make a decision between power consumption and message latency.

Although IEEE 802.15.4 is a popular choice for its low power consumption, bandwidth utilization is still an important problem both for the performance and power consumption of wireless sensor networks. Some applications, like body sensor networks, require sensor nodes to sample data at the same time or respond to events and collision probability is increased with the network size. Increase in collisions result reduction in bandwidth utilization which triggers increase in energy consumption and message latency. In order to solve this problem, several methods, such as slot assignment methods, have been proposed and it will also be considered for IS-ACTIVE sensor network development.

4.3. WSN focus in IS-ACTIVE

With respect to the IS-ACTIVE architecture, the focus from the WSN point of view is:

- At the sensor node level:
 - Optimized hardware design for a wearable node
 - Miniaturized on-board integration of inertial sensors
- At the sensor network level
 - Physical and Data link / MAC layers, with focus on efficient, ad-hoc, one-hop communication, multi-hop networking aspects being less relevant
 - Cross-layer networking – sensing features for facilitating instant user interaction, activity/inactivity detection, wake-up on activity detection etc.

5. Interactive devices

Interactive devices create a seamlessly relationship between the end-user's daily life and the IS-ACTIVE sensor-based infrastructure. The latter comprises a non-visible technology infrastructure for the patient who is not going to interact hands-on with it. In order to incorporate this technology to the user daily life, interactive devices are required to bridge the functionalities of the system with the patient's routines and physical treatment. The interactive

devices refer to all those devices with which the end-user will interact in different ways to receive suitable and tailored feedback about their physical state and training progress. These devices will monitor and evaluate patient's physical state in an unobtrusive way and provide feedback for physical training. They will stimulate and encourage physical activity for COPD patients to explore self-monitoring of their physical condition, while improving social and emotional communication with other COPD patients, separated friends and caregivers.

We made an initial categorization of these interactive devices based on the main functionality served for the user (Figure 6).

- Technology Aided Objects (guidance and training coaching)
- On-Body Sensor devices (monitoring user's vital signs)
- Feedback Devices (communication with caregivers and final feedback)

In order to persuade COPD patients to modify their behaviour towards improving their physical condition, these devices should trigger engagement with natural and meaningful interactions, drawing the benefits that physical activity can bring to their current health status, adding value to their daily life. Special attention should be taken regarding the people's relationship to new technology and their technology literacy. For instance, it is commonly known that many elderly people are not familiar with technology, demanding a design of simple interfaces with emotional valuable interactions.

Different scenarios can be considered regarding how the user interacts with the IS-ACTIVE sensor-based infrastructure, and how the interactive devices are interconnected to provide feedback to the user. Besides, when defining the characteristics of the needed feedback for the user both the functionality and usability of the interactive devices would also vary. A single device that serves as On-Body Sensor and a Feedback Device require different specifications. It would receive patient's enquiries and wishes and communicate this information to the Care Supervision, while monitoring kinetic behaviour and provide him/her feedback about his/her physical status in a portable way; the mobile phone is a practical example of this interaction.

A general description about how the user interacts with these devices and what kind of feedback he/she would send and receive from them is depicted in Figure 5. However, the final scenario and the adopted functionality and interactions on a single device will be part of user-centred design research with end-users, carrying on for this project.

In the following, we describe the initial characteristics of these devices and the different nature of the interaction with the user.

5.1. Technology aided objects (TAOs)

These objects comprise technology enhancements to monitor and assess the physical training performance for COPD patients. They are mainly graspable objects to coach and guide the patients with their training program (stretching, strengthening muscles, breathing) at home and outdoors, encouraging physical activity and self-monitoring along with virtual training groups.

They will persuade COPD patients to follow daily routines and guide them to perform the suggested physical exercises in a correct way. Therefore, these devices will provide low-level feedback in the form of immediate and short information while carrying out a physical exercise.

It might be possible that these TAOs will stand out from the home environment in order to remind COPD patients the daily training sessions and keep them actively enthusiastic to improve their physical condition. It is important to create emotional attachments (trust and value) with playful and pleasurable interactions in order to guarantee daily and long usage.

- Equipping objects with sensors
- Indoors (fitness)
- Outdoors (bike, walking stick)

5.2. On-body sensors

These devices will monitor vital signs, such as heartbeat, breathing, blood oxygen saturation and motion tracking. They will be attached to the patient's body in an unobtrusive and comfortable way to wear for long periods, even while sleeping. Although, they do not have a special shape to interact with the user, and they aim to be invisible for the user, they should encourage patients to use the sensor daily. Therefore, the design should consider a non-invasive measurement of vital signs, simple structure and small size.

Two main categories of on-body sensors to be used in IS-ACTIVE are:

- Physiological monitoring
- Inertial monitoring

5.3. Feedback devices

These devices are targeted to manage a high-level feedback for the user in three different ways. First, they will communicate the information sent by the networked system to the user (Tangible Aided Objects, On-Body sensors, Environmental Sensors,) in a form of assessed information about physical status, training program history or environmental reports. Second, they will serve as a communication bridge between caregivers and the patient (Virtual Training Groups, doctors and nurses). Finally, they will enhance motivation for physical activity. In order to translate this feedback to the user a multi-modal sensory interaction should be applied for these devices. It means, the way the user interacts with these devices relies on displaying, receiving, accessing and sending information whether with visual, auditory or tangible interfaces in order to access to information regarding the patient's training, physical state, personal progress, messages, advices, warnings, invitations, notifications, etc.

A single Feedback Device would serve as a centralized device not only to provide low and high level feedback, but also to monitor activity. It is also possible that a single device is enabled to communicate a specific feedback to the user (for instance a desk lamp that communicate and encourage the patient to exercise). Since the feedback on activity should be given while the patient is outside and on the move, the device to give the feedback on should be portable. However, the interaction should consider the user's context, desires and needs in order to define the most suitable device. For instance, there is a general idea that communicating feedback on already daily-life objects would enable intuitive and natural interactions, increasing the user-acceptance and truthfulness. These objects comprise those already embedded in user's home and life, such as TV, lamps, mobile and computer. It is also important to consider that these devices will serve mainly for elderly people, so that simple devices are required to accomplish the interaction with ease.

In what follows we discuss a list of possible feedback devices and their suitability for giving feedback on activity and exercises:

- *TV*. It is an integrated central device into people's daily life and patients are very likely to be familiar with it. The TV offers a yet intuitive interface, making this a good opportunity to provide suitable feedback, especially for elderly people that consider this device more than a mere entertainment device, but also as a "comforting friend" and the gate to the exterior world.

All newer types of TVs can easily be connected to a computer making it an ideal candidate for a large, central feedback device. Television screens are usually quite large and come with speakers, so there is much space for visual feedback and audio feedback as well. Because of its large range of capabilities, the TV would be suitable for feedback on activities as well as feedback on exercises.

- *Ambient devices.* Calm-technology is a good way to provide interaction in an inconspicuous and unobtrusive way for patient's daily life. The technology embedded in familiar objects, already domestic would trigger even more emotional and social interactions, since they represent a compelling-appealing information station. This characteristic enables a more friendly way to communicate physical status or remind daily training. For instance, a lamp that can be programmed to emit different colored light can be a simple but effective feedback device. It can be placed anywhere in the home environment, and people will not associate it with a medical feedback device. On request of the user, the device could emit a yellow light if the patient has not been active enough or a green light if the patient has passed his goals. The percentage of the activity goal of the day reached can in this way be displayed in a red-green gradient.

There is a good chance to explore daily user's experiences with symbolic objects to provoke a pleasurable way to provide information to the networked system, and receive it as a form of feedback. The passive interaction of calm-technology seems to be more sincere in a sense of displaying information with a more pleasurable presentation. However, these devices might not allow for feedback in any more detail and thus has the risk of being slightly vague. Because of its limited capabilities it would also only be suitable as reminders or incentive for keep on training.

- *Computer.* A computer screen (possibly in combination with speakers) has the same capabilities as a TV. A difference is that COPD patients might not be as familiar with the PC-setup as compared to a TV. It is also a device that is usually less central in the patient's home environment and may even need to be installed separately. Can be used for feedback on activities and feedback on exercises.
- *Mobile phone / PDA.* Currently, mobile solutions are one of the widely used gateway for ambient intelligence systems. A mobile phone or PDA would act as a main gateway and interface for the user with the technology infrastructure. A centred device would be used to access and facilitate the communication between patients, caregivers and friends remotely (outdoors and indoors), while providing feedback about physical status. A PDA can be carried around by the patient and is thus suitable for giving feedback on activities while the patient is on the move. Most PDA's have quite a lot of computing power and can thus be used as a processing node in the wireless sensor network, possibly computing the feedback strategy itself. This device would become in the user's personal trusted terminal for interaction with the Ambient System.

A disadvantage is that the small screen and touch-based interface might not be suitable to COPD patients as they are unfamiliar with the technology. Elderly patients would find this particularly frustrating due to complex interfaces and usage difficulties, decreasing self-motivation making harder the acceptance of a new device. However, some target users seem to be familiar with integrated technologies (mobile and touch-based interfaces) into their daily life.

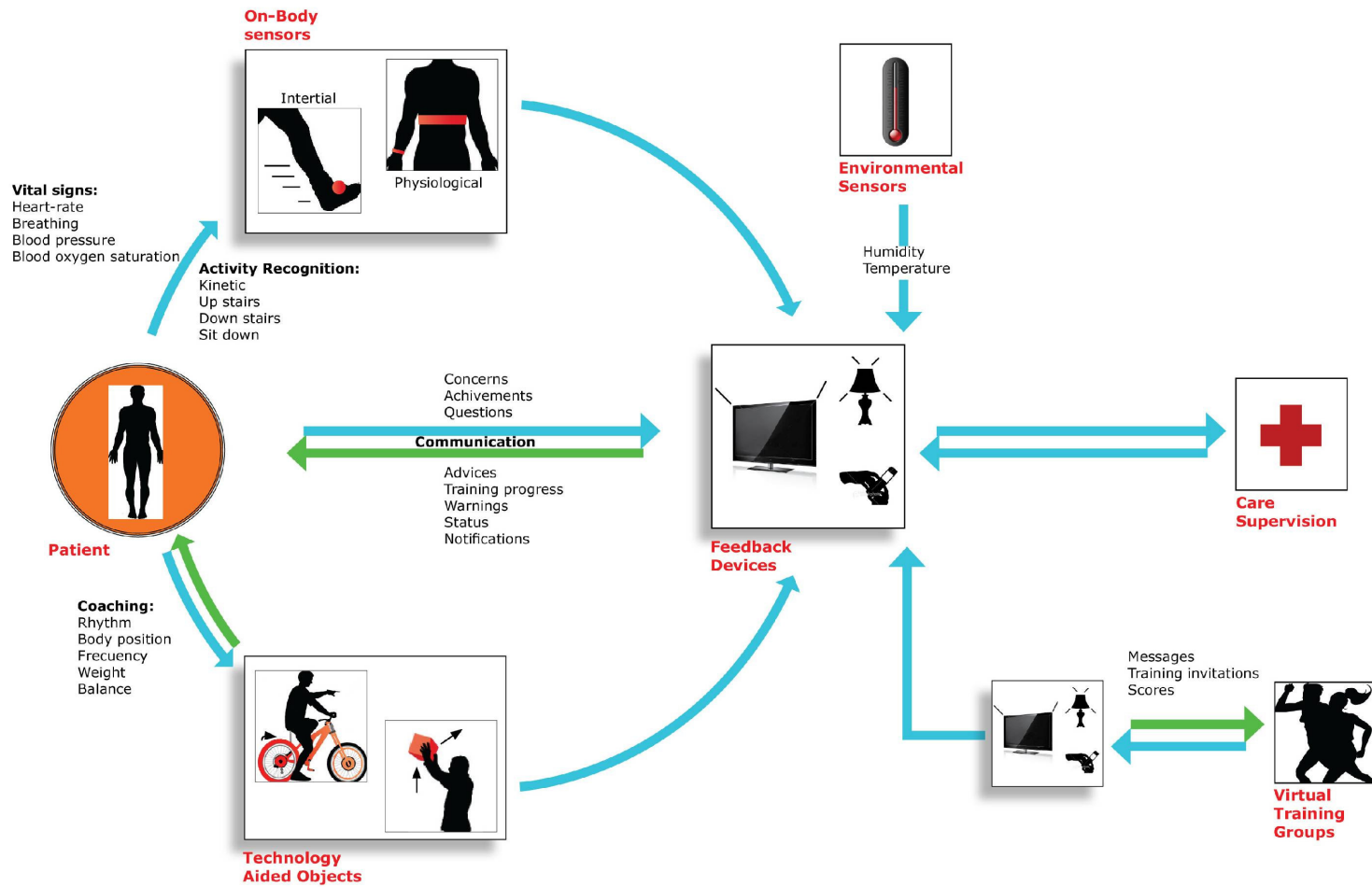

Figure 5 – Overview of user interaction

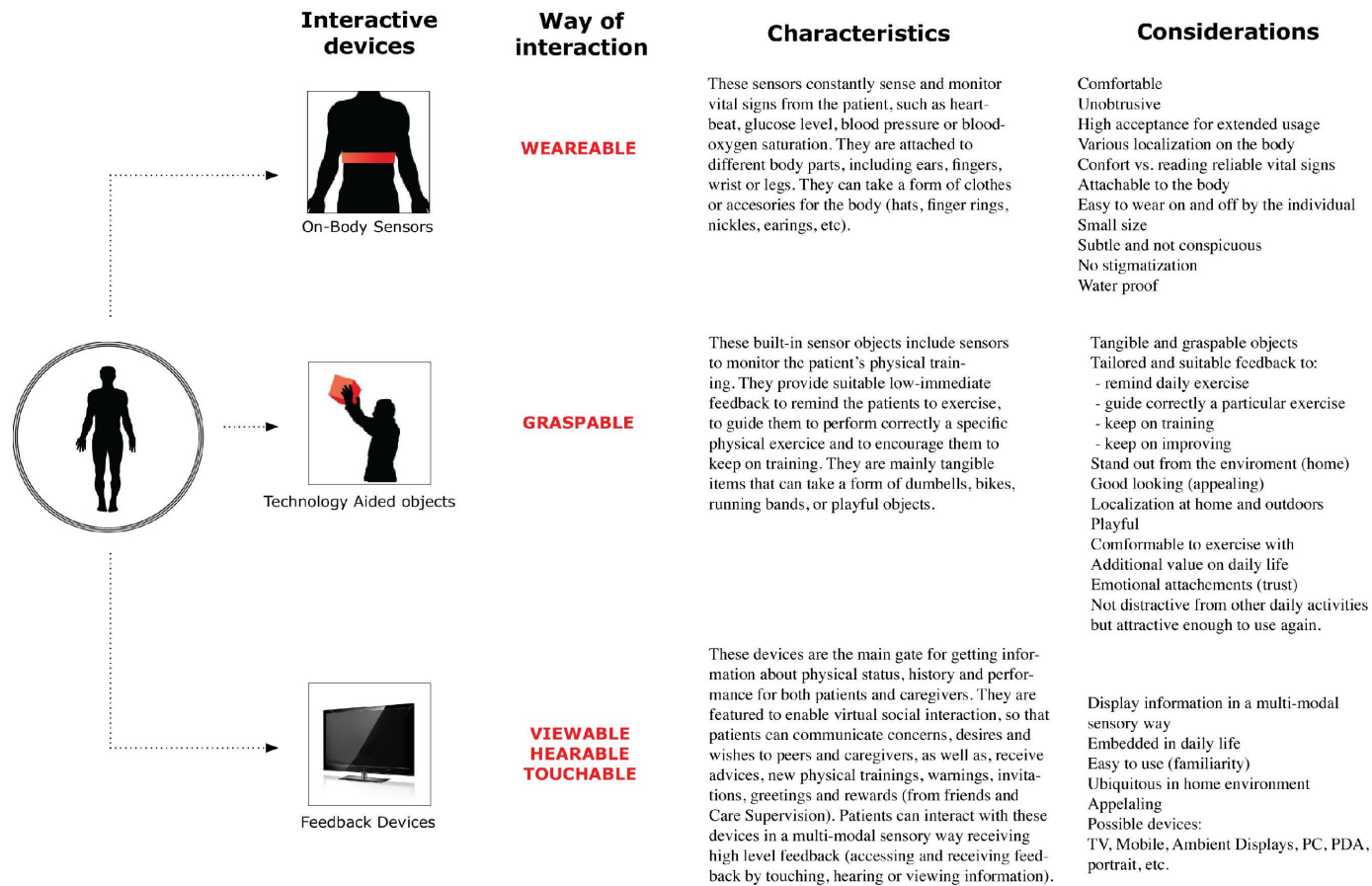

Figure 6 – Detailed considerations on interactive devices

6. Infrastructure

With respect to Figure 1, the infrastructure components concern the home-based infrastructure, the extension to multi-users and the connection to the caregiver.

6.1. Home-based infrastructure

Beneficial data collected by the inertial and physiological sensors, interactive objects, and environmental sensors is needed to be gathered together in order to achieve valuable results about patient status and present feedback to the user. For this purpose, a home-based wireless infrastructure interacting with all these building blocks of the IS-ACTIVE system is needed. Some of the possible technologies and protocols, which can be used as the home-based infrastructure, are briefly discussed below:

- **IEEE 802.15.4 / ZigBee:** IEEE 802.15.4 defines the physical and MAC layer, and it is suitable for wireless sensor applications. Details of 802.15.4 are discussed in Section 4.2 Sensor networking. Similar to 802.15.4, ZigBee protocol provide the network infrastructure required for wireless sensor network applications, but it defines the network and application layers. Design concerns of ZigBee are similar to IEEE 802.15.4 protocol. Some of the typical applications are personal healthcare, building automation, consumer electronics, industrial control and home control. Both ZigBee and IEEE 802.15.4 specifications are intended to be simpler and less expensive than other wireless personal area networks, such as Bluetooth.
- **Bluetooth:** Bluetooth was first designed as a wireless alternative to RS-232 serial communication protocol and it is now one of the widely used short range wireless personal area networks. It is also designed for low power consumption based on low cost microchips. Because of these reasons, it can be found on many devices such as mobile phones, PDAs, Wii, headsets, Lego Mindstorms NXT, and PCs. The widespread applications and usage of Bluetooth enables an easy construction of personal area network especially for a home environment.
- **WiFi:** WiFi, namely IEEE 802.11, can be defined as the wireless version of the well-known Ethernet network. It requires a pre-configuration to set up connection, however it has a faster connection, better range and better security than Bluetooth. One of the main advantages of WiFi is its widespread usage in today's' home environments which might prevent us from the burden of setting up a home-based infrastructure.

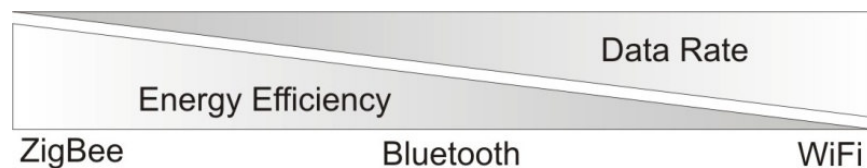

Figure 7 - Relation between wireless communication protocols

6.2. Multiple users/patients

The following requirements regarding the possibility of exercising, gaming, and for the patients to use the IS-ACTIVE system together are stated in the requirements analysis of deliverable D2.1 section 6.2 (functional requirements) point 4.5:

The system must comprise group training and exercises, so the patient can perform the normally individual exercises (see supplement) in a group

- *The system must be able to communicate with other patients.*
- *The patients belonging to one group must be networked.*
- *The individual treatment goals of the exercise performed as a group should be shown to the group as relative treatment goals on the feedback device.*
- *Besides the personal treatment goal of each individual patient, the group must have a predefined activity goal, set by the system.*
- *Besides the individual feedback, the group must receive feedback concerning the group activity goal, based on the data from the on-body sensors and the inertial sensors incorporated in the fitness devices.*

Partners have indicated this as M (must have) for NST, C (could have) for ELS and W (won't have) for RRD.

In order to support real-time cooperation between IS-ACTIVE users at different locations there has to be used devices able to communicate either directly with each other or with a common network attached server. Using the internet protocol to coordinate actions and data among participants is the easiest and most flexible way of implementing a higher level application, even though this limits the feedback devices to those who are internet enabled. However, most devices can access internet; mobile phones over GPRS, many phones and most PDA's over WiFi, and a residential communication device over WiFi and cable networks.

The required capabilities of a feedback device depend on the requirements of the applications to be supported.

Users exercising together in a "virtual world" would require a powerful residential feedback device, as each party has to run a server (in the case of SUN's Wonderland). Also, common exercising supported by multipart video stream could require each site to run videoconferencing software. However, smaller and lighter applications could be supported on a mobile phone using a java application, using animated symbols for the other participants and just communication status messages between the participant's devices.

6.3. Communication with the caregiver

From D2.1, there are four specific requirements that involve communication with a healthcare professional or caregiver:

9.1. The physiotherapist OR a nurse (preferably pulmonary) must have access to the patient's data in order to monitor progress by the Personal Health Record (C: ELS, NST, RRD) by a personal log in.

9.2. The device must generate weekly reports about the patient's status, with all the measured data. This could be incorporated in a Personal Health Record so

the healthcare professional can monitor the patient's progress. (S: ELS, NST, RRD)

9.3. The healthcare professional must be able to send a personal message to the feedback device of the IS-ACTIVE system of the patient. (C: ELS, NST, RRD)

9.4. The patient must be able to choose the amount of supervision (no supervision option: patient sets own goals, or professional supervision option: physiotherapist sets goals, and extra guidance sessions with physiotherapist). (M: NST; W: ELS, RRD)

(M must have S should have C could have W won't have)

None of the partners have indicated the requirements 9.1 – 9.3 as “must have”. This could mean that they are less important for the IS-ACTIVE system – if they e.g. lead to a complicated architecture, costly development, or complicated usage of the system.

An architecture supporting these requirements depends on the capabilities of the feedback devices and communication systems at hand. Possible patient feedback devices will include PDA, TV (with dedicated computer/set-top-box) or a PC/laptop. Permanent data storage can in principle be implemented on all the mentioned feedback devices, in addition to storage on a secure server on the Internet or at the healthcare provider. If, for example, a user has a PDA as the only feedback device, in addition to the IS-ACTIVE sensors, the most suitable place to store the information could be either on the PDA, on a personal computer at home, or on a server on the Internet. Data can even be saved by sending SMS/MMS messages to a remote server, or sending them directly into the health care provider's information system.

Looking closer at the requirements, both **requirements 9.1 and 9.2** dictate that the system must provide storage for the patient's data over time and make it accessible from outside/others. The caregiver needs to be able to get a rich representation of data in the form of progress reports, so the use of a standard internet connection is a preferred option.

Requirement 9.3 can be satisfied by allowing care givers to send text/mms messages to the patient's cell phone/PDA, although the availability of a dedicated internet connection to the IS-Active's main device (if the user only have a PDA, he or she will we need a “main” device in addition at home or a an Internet server) opens up a broader range of possibilities using dedicated internet application or even email.

To satisfy **requirement 9.4**, the system must provide an interface for changing the goals for the patient (in terms of which activity level should be reached, which exercises should be performed and how often the guidance sessions with the physiotherapist should occur). This interface could be implemented as a local feature, where the caregiver can access it during house-visits, but preferably it can be accessed remotely, over the internet.

It is possible to envisage alternative setups. One setup that would satisfy all four above mentioned requirements would put the main IS-Active device at the patient's home in the role of a web-server that serves a simple web portal (the residential **Communication Portal**). The patient's caregivers would each have access to the portal with a username and password. In this case, each individual caregiver can, after logging in, be presented with their specific services. For example, family and friends can login to send a message

to the patient, while an authorized physiotherapist can access the interface to change activity goals and guidance session schedules, but can also see the weekly progress reports, generated by the system. This requires the main IS-Active device to be a PC with a dedicated internet connection, running for example Apache/PHP/MySQL to run the Communication Portal. However, allowing remote login to a residential Communication Portal does require high levels of security in order to avoid unauthorized access or hacking.

Another setup could be to have a server on the Internet for storage of information to be shared, that can be accessed by the patients and the healthcare personnel. The server is then acting as the IS-ACTIVE main device.

There are pros and cons of all the setups, and IS-ACTIVE could support one setup or several. It will depend on the services and feedback devices a patient is using, e.g. if a patient has a TV, PDA and/or PC device, and where to put a main (storage) device.

6.3.1. Internal Home Device

An Internal Home Device may be needed for the following services:

- Storage of user activity data, user profile, preferences, progress etc.
- Gateway to other patients/users and to the caregiver through broadband connection;
- Videoconference;
- Data encryption and privacy;
- Virtual private networking (VPN);

The Internal Home Device could be implemented on an embedded PC or on mobile computing platforms (e.g. mobile phone, PDA), depending on the complexity of the software running on it.

6.3.2. Communication Portal

A Communication Portal may be developed with the following objectives:

- Communication and information exchange;
- Virtual-world exercising;
- Peer-to-peer exercising with videoconference support

7. Functional overview

In accordance with the requirements analysis, the IS-ACTIVE architecture should support two main lines of functionality:

- *Activity monitoring* – monitoring of physical activity in daily life. The system monitors the amount of activity, type of activity, distribution of activity (daily activity pattern), activity intensity and certain types of activities like walking. Patients receive feedback about their activity in order to improve physical condition and quality of life.

- *Exercise coaching* – short-term, occasional training with specially-designed COPD exercises, so that the exercise performance can be assessed. Patients receive feedback about the right execution of the exercise and safety.

In the following we present the functional architectural overview, with respect to the two lines of functionality mentioned above. For each case, we structure the presentation in ordered steps. The reader is also referred for reference to the top-level architectural view from Figure 1.

7.1. Activity monitoring

Main characteristics:

- The primary technical concern is to ensure an optimal trade-off among performance (accuracy of activity monitoring), energy efficiency (for long-term operation of the system) and usability (simple to use, wear etc).
- Because of energy efficiency and usability aspects, only a small subset of sensors from the BSN should be used. For simple activity monitoring, to assess the amount of activity for example, only one sensor node equipped with an accelerometer might be sufficient.
- Feedback should be provided in the form of summaries of long-term assessment of the user activity, but also – on a daily basis..
- Summaries of the activity results are primarily targeted for the patient himself, but *could* be presented to caregivers as well.

Functional flow, organized in steps of operation involving various architectural components from Figure 1:

Step 1: On-body sensor nodes. The user is assumed to wear at least one sensor node equipped with inertial sensors. The sensors are sampled at low data rates, in order to minimize power consumption. For the same reason, the wireless communication is maintained at a low duty cycle.

Step 2: BSN. The sensory information is processed locally and summarized activity measures are extracted. If the user wears more sensor nodes, only these summarized measures are communicated among the nodes.

Step 3: TAOs. If the user interacts with TAOs, the sensor nodes embedded in TAOs will communicate with the on-body node(s). This information will be used for a better recognition of activities and subsequently for a more accurate estimation of activity measures (e.g. energy expenditure level).

Step 4: Feedback devices. Feedback is provided using the home-based wireless infrastructure and an appropriate and accessible feedback device. The feedback is meant to stimulate and coach the patient in achieving an optimal spread of activity, defined in the system-generated (and user-approved) activity goals.

Step 4b: A special type of feedback is represented by warnings or alarms. These can be triggered for example if the environmental conditions (e.g. air quality) are improper for the type of activity performed by the user (e.g. the system has inferred that the user is starting to cycle outdoors).

Step 5: Care center. At regular, predefined time instances, the summary activity information can be uploaded to the care center.

7.2. Exercise coaching

Main characteristics:

- The primary technical concern is to provide accurate interpretation of the user's motions, along with motivating coaching during exercising. Energy efficiency is not a major concern due to the relatively short duration of the exercises.
- The BSN plus TAOs are involved to create a sensor-enhanced exercising experience to the user. Multi-source, multi-type sensor information is needed for accurate tracking of user motion. Additionally, physiological sensors should be in the loop, in order to ensure the safety limits of user's capabilities.
- Feedback should be provided in a way that stimulates the correct and complete execution of the training exercises.
- The connection with the care center is less relevant. Possibly overall metrics characterizing the performance during training could be reported to the care giver for post-analysis.

Functional flow, organized in steps of operation involving various architectural components from Figure 1:

Step 1: On-body sensor nodes. The user is assumed to wear multiple sensor nodes equipped with various types of inertial sensors. The sensors are sampled at much higher rates than in the case of activity monitoring, in order to recreate the body kinematics necessary for the exercise coaching.

Step 2: BSN and TAOs. The sensory information is processed locally and features of interest are extracted from the continuous stream of data. Features of interest from multiple nodes (worn on-body and embedded in the TAOs) are aggregated to produce a complete image of how the user is performing the training exercise.

Step 3: Feedback devices. The results of the previous step are utilized to adapt continuously the feedback to the current exercise step and to provide motivating coaching, for example in form of a gaming experience. The wireless home infrastructure is used to connect the BSN and TAOs to the feedback devices.

Step 4b: A special type of feedback is represented by warnings or alarms that should be triggered if, during the exercise, the user is exceeding the safety limits, for example as sensed by the physiological sensors.

Step 4: Multiple users/patients. The exercising experience can be enhanced by multi-user training and gaming. The feedback should be adapted to offer group coaching or, depending on the exact case, competitive stimulation among users/players.

Step 5: Care center. As previously mentioned, the connection to the care center is less relevant in this case. Summary performance metrics can be uploaded to the care center for monitoring user's progress.

8. Conclusions

This document presented the top-down IS-ACTIVE architecture, starting from the high-level view, detailing each important building block and eventually giving a step-by-step functional overview.

Together with the requirements analysis from D2.1, the architecture specification described herein leads us to the following priority points for development and implementation:

- Sensor technology level:
 - Hardware design for miniaturized, potentially wearable sensor nodes integrating inertial sensors
 - Sensor networking supporting ad-hoc, one-hop wireless communication
 - Network integration of physiological sensors (off-the-shelf)
- Algorithmic level:
 - Activity monitoring and recognition
 - Human motion tracking in physical exercising
- User interaction level:
 - Design and networking of technology aided objects
 - Motivating feedback and coaching

The infrastructure level is left relatively open and flexible, since the IS-ACTIVE scenarios have different requirements in this respect, from user-centered (e.g. mobile phone) to completely centralized (e.g. caregiver portal). System adaptations will have to be made therefore during the experiments and field trials to match the requirements of the specific infrastructure.

9. References

[Zimm80] Zimmermann, Hubert. *OSI Reference Model - The ISO Model of Architecture for Open Systems Interconnection*. 4, s.l.: IEEE Transactions on Communications, 1980, Vols. COM-28.

[Dain08] Daintree Networks. *Getting Started with ZigBee and IEEE 802.15.4*. [Online] Feb2008.http://www.daintree.net/downloads/whitepapers/zigbee_primer.pdf?04689c51410dea3ab5cc32b2b01c7ae7=b8b9acddafaf784efd56afe3947ff08f.

[IEEE06] IEEE Computer Society. *IEEE Standard 802.15.4-2006*. Sep 2006. <http://standards.ieee.org/getieee802/download/802.15.4-2006.pdf>.

[Char09] Charfi, Walid and Masmoudi, Mohamed and Derbel, Faouzi. *A LAYERED MODEL FOR WIRELESS SENSOR NETWORKS*. 2009 6th International Multi-Conference on Systems, Signals and Devices.

[Sohr00] K. Sohrabi, J. Gao, V. Ailawadhi, and G.J. Pottie. Protocols for self-organization of a wireless sensor network. *IEEE Personal Communications*, 7(5):16–27, Oct 2000.